

NVE

A Partnership *for* Success

COMMERCIAL DUTY

Defender 500

VACUUM PUMP

Ballast Port Cooling
for Extended Use in
Severe Conditions

*Superior
Design!*

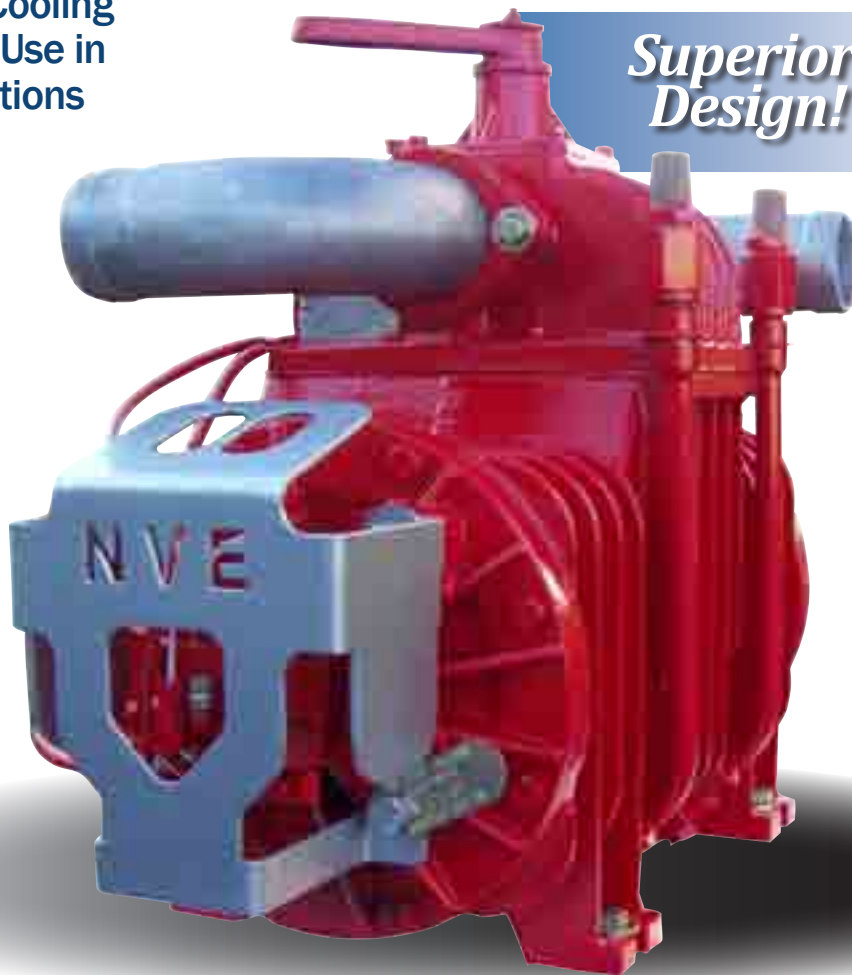

Ballast Port Cooled



National Vacuum Equipment

P.O. Box 685
Traverse City, MI 49685 USA
800-253-5500 | sales@natvac.com

Arkansas Distribution Center

1612 Warehouse Drive
Fayetteville, AR 72701
479-409-7331, 479-409-6748 | Fax 479-444-8211

natvac.com

NVE Defender 500 - Ballast Port Cooled

Our Challenger Series pumps are designed and built with the customer in mind – resulting in dependable, high performing pumps that are easy to install, operate and service. **Compare and you will see that our superior design beats the competition on the following:**

- **One Piece Shaft Design**
- **Remote Oil Tank**
- **Oiled Bearings, Front & Back**
- **Heat Resistant Viton Seals**
- **4 Port Oil Pump for Controlled Delivery**
- 310 cfm at 1200 rpm
- RPM Range 1000 - 1200
- Max Intermittent Pressure 21 PSI
- 18 Horsepower
- Automatic Lubrication
- 4-Way Change Over Valve
- 3" Swivel Elbows
- Heat Resistant Kevlar Vanes
- **Built and Supported in the USA**

Defender 500

Dimensions: 13" W x 31.6" L x 21.7" H
Weight: 397 Lbs.

Model #108-500-D (CW)
Model #108-500-S (CCW)

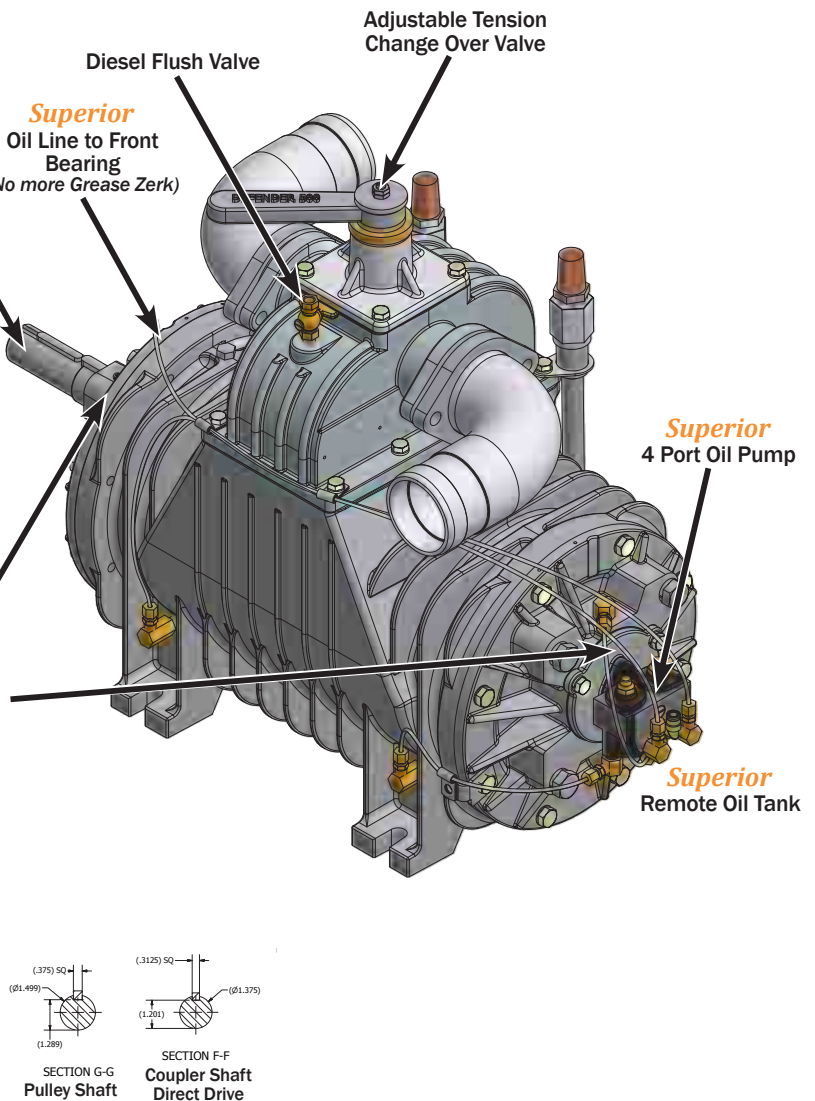
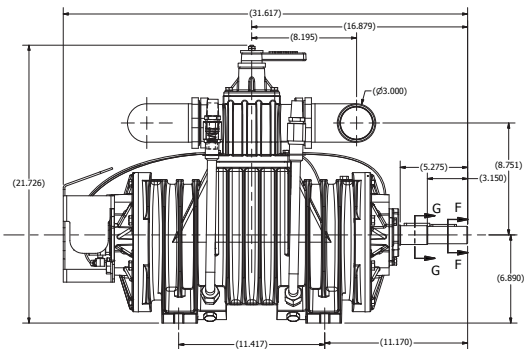
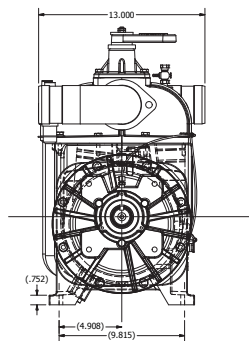

All specifications subject to change without notice.

National Vacuum Equipment

P.O. Box 685
Traverse City, MI 49685 USA
800-253-5500 | sales@natvac.com



Arkansas Distribution Center

1612 Warehouse Drive
Fayetteville, AR 72701
479-409-7331, 479-409-6748 | Fax 479-444-8211